



# MEAS



High reliability at high speed machining of aluminum

Serrated insert pocket to resist centrifugal force to ensure stable, high speed machining

3-axis machining with a max. ramping angle of 20° (ø25)

PDL025 achieves long tool life with hardness close to that of diamond



Modular type available and  
extended face mill lineup



High efficiency end mill for aluminum machining

# MEAS

Excellent chatter prevention to ensure stable, high speed aluminum machining. 3-axis machining with large ramping angle for a wide range of machining applications.

## 1 High reliability and high efficiency machining

Serrated connection between the insert and holder provides high speed aluminum machining ( $\phi 32$ : recommended max. cutting speed  $V_c = 3,000$  m/min)

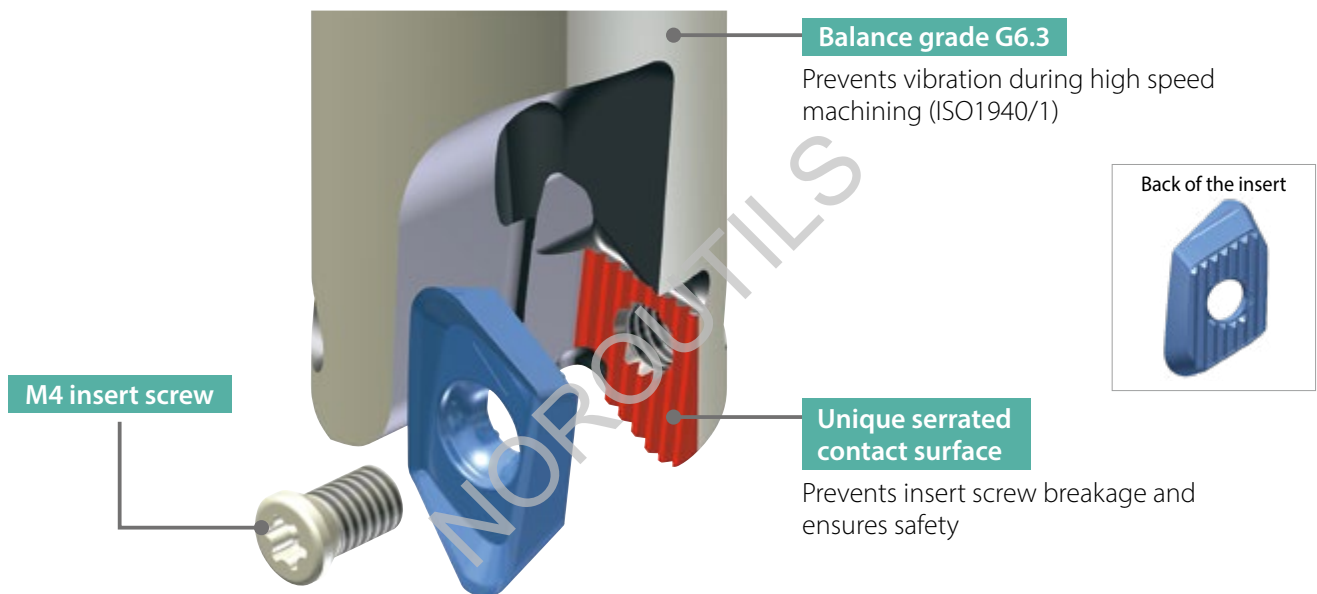

### Serrated insert pocket

Centrifugal force is applied across the grooved surface to reduce pressure on the insert screw. Prevents insert screw breakage and safely secures the insert during high-speed revolutions

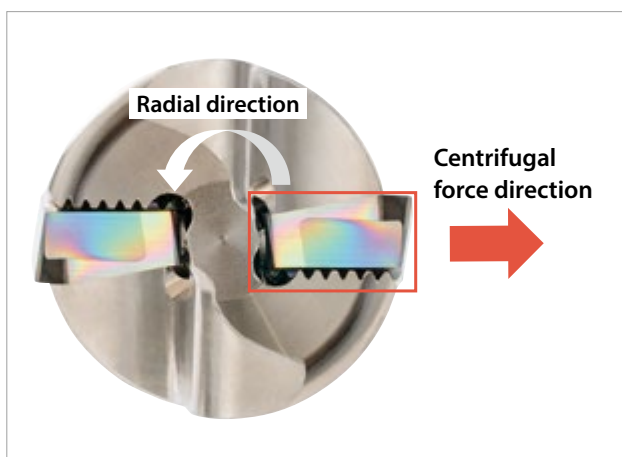

### Serrated contact surface

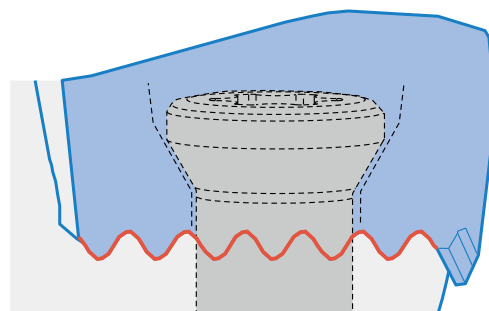

## 2 Low cutting force with sharp cutting edge

True rake angle max. 20°  
 Low cutting force and excellent chattering resistance

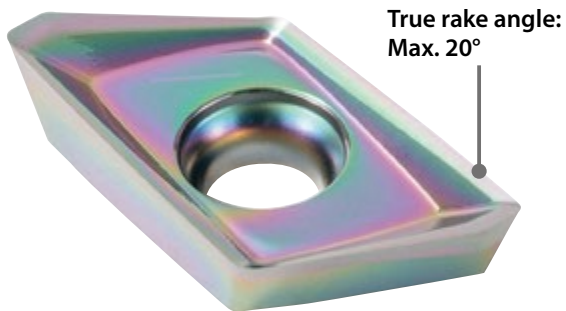

Cutting force comparison (In-house evaluation)

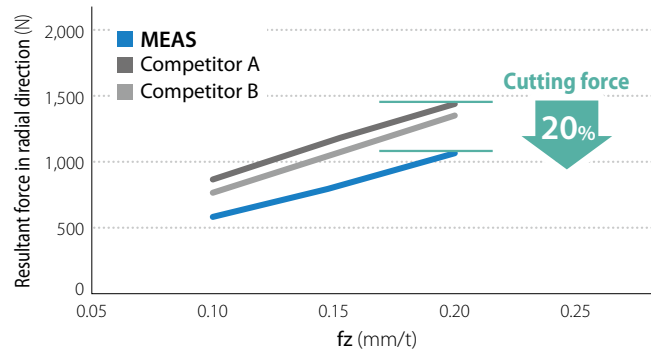

Cutting conditions:  $V_c = 390$  m/min,  $a_p \times a_e = 8 \times 5$  mm, dry  
 Cutter dia.  $\varnothing 25$  mm (2 inserts) Workpiece: AlZnMgCu1.5

## 3 Machining for a wide variety of applications

Max. ramping angle 20° ( $\varnothing 25$ )

The MEAS can be used for shouldering, slotting, ramping, and helical milling applications

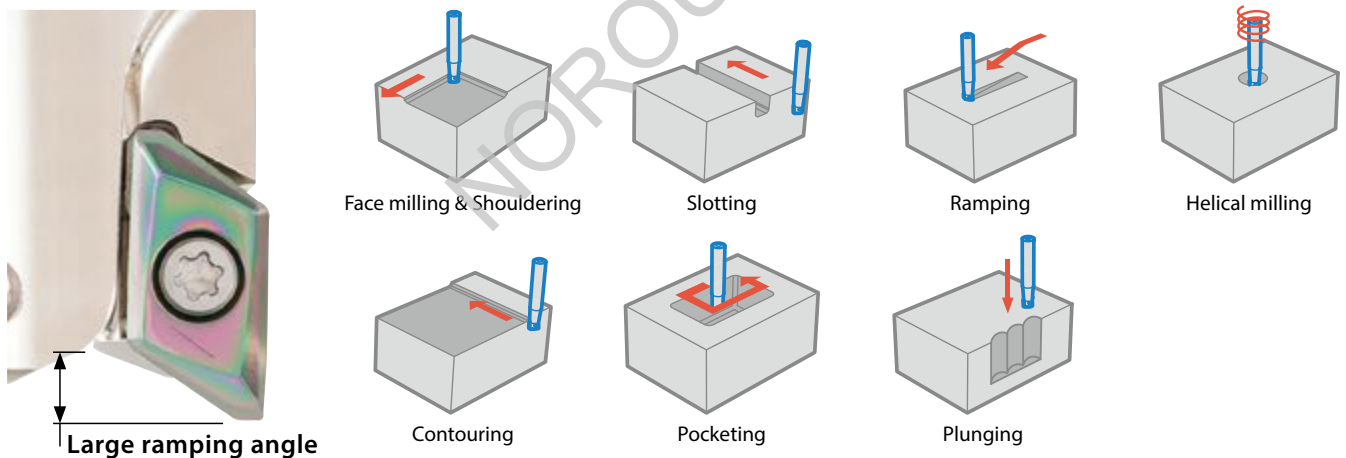

### Two different chipbreaker available

AL chipbreaker with low cutting force design

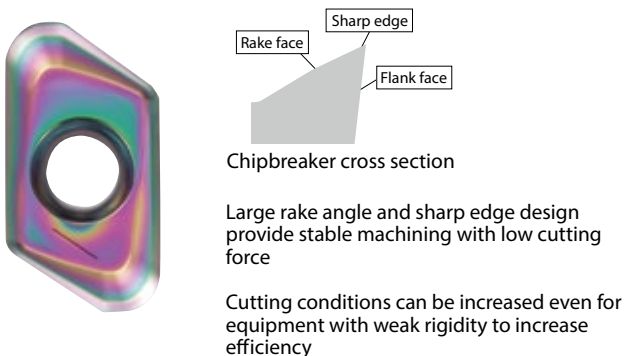

AM chipbreaker with tough edge



## MEAS | End mill

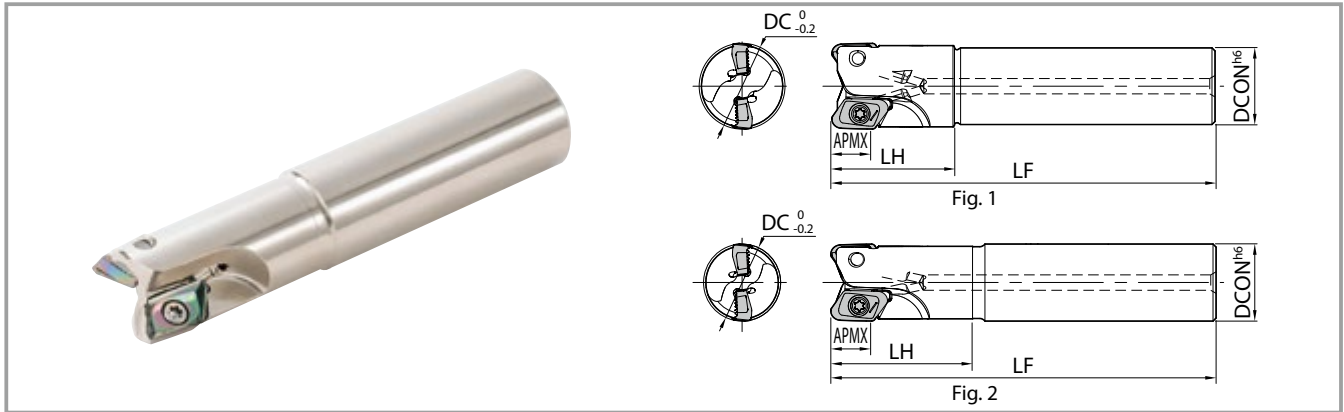

### Toolholder dimensions

Description		Availability	No. of inserts	Dimensions (mm)						Rake angle		Coolant hole	Weight (kg)	Drawing	Spare parts			Max. revolution (min <sup>-1</sup> )
				DC	DCON	LF	LH	APMX	A.R. (MAX.)	R.R.	Clamp screw				Wrench	Anti-seize compound		
Straight shank	Standard	MEAS 28-S25-13-2T	●	2	28	25	125	40	12	+10°	-13°	Yes	0.4	Fig. 1	SB-4090TRP	DTPM-15 Recommended torque for insert clamp 3.5 N·m	P-37	54,000
		MEAS 35-S32-13-2T	●		35	32	150	50										46,000
		MEAS 40-S32-13-3T	●	3	40	50	50	42,000										
	Same size	MEAS 25-S25-13-2T	●	2	25	25	125	49	12	+10°	-14°	Yes	0.4	Fig. 2	SB-4075TRP			59,000
		MEAS 32-S32-13-2T	●		32	32	150	69										49,000
		MEAS 25-S25-13-2T-170	●	2	25	25	170	89										49,000
Long	MEAS 32-S32-13-2T-200	●	2	32	32	200	119	12	+10°	-13°	Yes	1.1	Fig. 2	SB-4090TRP	39,000			

When using inserts with a corner-R (RE) of 3.2 or larger, additional modifications (R3.5 mm or larger) on the corner of cutter body is necessary.

If corner-radius is 3.0 mm or smaller, additional modifications are not needed.

Coat Anti-seize compound (P-37) thinly on portion of taper and thread when insert is fixed.

●: Available

## MEAS | Face mill

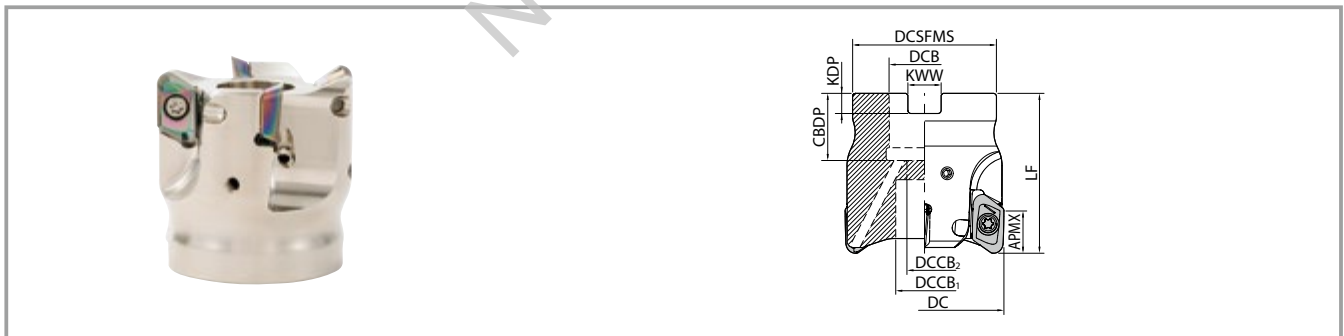

### Toolholder dimensions

Description		Availability	No. of inserts	Dimensions (mm)										Rake angle		Coolant hole	Weight (kg)	Spare parts				Max. revolution (min <sup>-1</sup> )	
				DC	DCSFMS	DCB	DCCB <sub>1</sub>	DCCB <sub>2</sub>	LF	CBDP	KDP	KWW	APMX	A.R. (MAX.)	R.R.			Clamp screw	Mounting bolt	Wrench	Anti-seize compound		
MEAS	040R-13-3T-M-KUA	●	3	40	38	16	14	9	40	18	5.6	8.4	12	+10°	-11°	Yes	0.3	SB-4090TRP	HH10X30H	DTPM-15 Recommended torque for insert clamp 3.5 N·m	P-37	44,000	
	050R-13-4T-M	●	4	50	45	22	18	11	50	21	6.3	10.4										0.4	36,000
	063R-13-5T-M-KUA	●	5	63	47	20	13	63	22	7	12.4	0.6										28,000	
	080R-13-5T-M-KUA	●	80	60	27	20	13	63	22	7	12.4	1.0										22,000	

When using inserts with a corner-R (RE) of 3.2 or larger, additional modifications (R3.5 mm or larger) on the corner of cutter body is necessary.

If corner-radius is 3.0 mm or smaller, additional modifications are not needed.

Coat Anti-seize compound (P-37) thinly on portion of taper and thread when insert is fixed.

●: Available

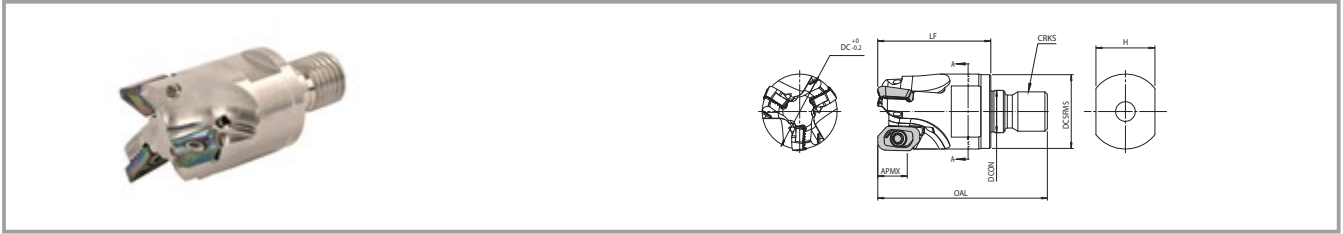

Toolholder dimensions

Description	Availability	No. of inserts	Dimensions (mm)									Rake angle		Coolant hole	Spare parts			Max. revolution (min <sup>-1</sup> )
			DC	DCSFMS	DCON	OAL	LF	CRKS	H	APMX	A.R. (MAX.)	R.R.	Clamp screw		Wrench	Anti-seize compound		
MEAS 25-M12-13-2T-KUA	●	2	25	23	12.5	63	40	M12xP1.75	19	12	+10°	-11°	Yes	SB-4075TRP	DTPM-15	P-37	49,000	
32-M16-13-3T-KUA	●	3	32	30	17	69	46	M16xP2.0	24					SB-4090TRP			39,000	

When using inserts with a corner-R (RE) of 3.2 or larger, additional modifications (R3.5 mm or larger) on the corner of cutter body is necessary. ● : Available  
 If corner-radius is 3.0 mm or smaller, additional modifications are not needed. Recommended torque for insert clamp 3.5 N·m.  
 Coat Anti-seize compound (P-37) thinly on portion of taper and thread when insert is fixed.

Applicable inserts

Shape	Description	Dimension (mm)					DLC coating
		W1	S	D1	L	RE	PDL025
	KCGT 130504FR-AL	9.9	5.1	4.4	14.1	0.4	●
	130508FR-AL				13.9	0.8	●
	130512FR-AL				13.8	1.2	●
	130516FR-AL				13.3	1.6	●
	130520FR-AL					2.0	●
	130524FR-AL					2.4	●
	130530FR-AL					3.0	●
	130532FR-AL				12.8	3.2	●
	130540FR-AL					4.0	●
	130550FR-AL					5.0	●
<p>Tough edge</p>	KCGT 130504ER-AM	9.9	5.1	4.4	13.7	0.4	●
	130508ER-AM				13.3	0.8	●
	130516ER-AM					1.6	●
	130525ER-AM				12.8	2.5	●
	130530ER-AM					3.0	●
	130540ER-AM				4.0	●	

● : Available

PDL025

Kyocera's proprietary hydrogen-free DLC coating  
 Achieves long tool life with hardness close to that of diamond

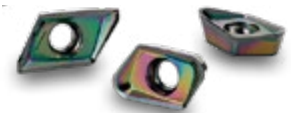

- 1 Long and stable tool life
- 2 Excellent surface finish
- 3 Stable machining

Coating properties (Internal evaluation)

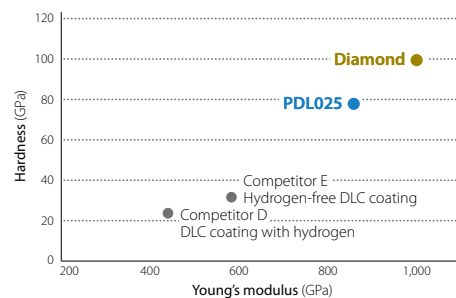

# Recommended cutting conditions

Workpiece		Chipbreaker	Cutting speed Vc (m/min)	Cutting diameter/Feed		
				ap = 0.5 mm (Reference value)		
				Cutting width ae (mm)	Cutting diameter DC	
Aluminum alloy	Si ratio 12.5% or below	AL	200 ~ <b>1,000</b> ~ 3,000	≤ 0.5DC	0.05 ~ <b>0.15</b> ~ 0.25	
				0.5DC <	0.05 ~ <b>0.15</b> ~ 0.25	
		AM	*200 ~ <b>1,000</b> ~ 5,000	≤ 0.5DC	0.05 ~ <b>0.15</b> ~ 0.3	0.05 ~ <b>0.2</b> ~ 0.35
				0.5DC <	0.05 ~ <b>0.15</b> ~ 0.25	0.05 ~ <b>0.15</b> ~ 0.3
	Si ratio 12.5% or above	AL	200 ~ <b>300</b> ~ 400	≤ 0.5DC	0.05 ~ <b>0.1</b> ~ 0.2	
				0.5DC <	0.05 ~ <b>0.1</b> ~ 0.2	
		AM	*200 ~ <b>300</b> ~ 800	≤ 0.5DC	0.05 ~ <b>0.15</b> ~ 0.3	0.05 ~ <b>0.2</b> ~ 0.35
				0.5DC <	0.05 ~ <b>0.15</b> ~ 0.25	0.05 ~ <b>0.15</b> ~ 0.3

- \*Please note that the cutting speed is different between AL chipbreaker and AM chipbreaker.
- Adjust the cutting speed and feed within the recommended machining range according to the actual cutting conditions. (machine rigidity, work rigidity, etc.)
- Do not use it under conditions that exceed the recommended conditions.
- When using at high speed rotation (10,000 min<sup>-1</sup> or more), take effective safety measures by adjusting the balance of the combination of the tool body and arbor at the speed you are using, referring to the balance grade table below.
- For high-speed machining, check the condition of the screws and replace them regularly. (When the cutting speed is 3,000 m/min, replace the screws when replacing inserts.)

## MEAS cutting performance

ø50 (4 inserts) shouldering ae = 25 mm Workpiece: AlZnMgCu1.5

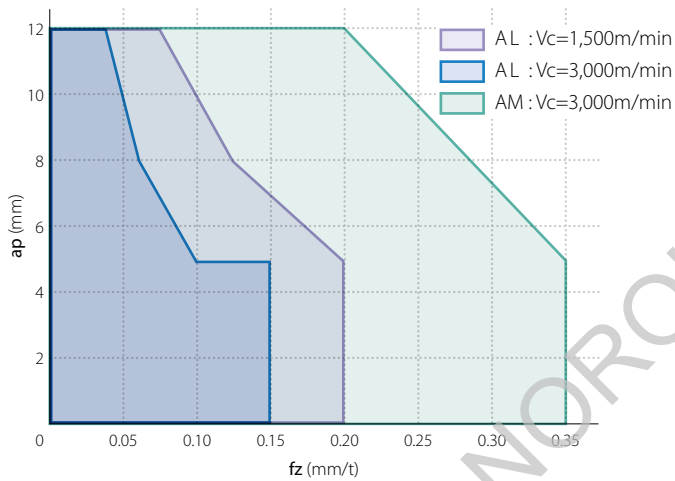

Spindle revolution (min <sup>-1</sup> )	ISO Balance grade ISO 1940-1/8821 (JIS B0905)
~ 20,000	G16
~ 30,000	G6.3
30,000 ~	G2.5

• Reduce the feed rate when machining at high speed.

## Max. revolution for each cutting diameter

Cutting diameter DC (mm)	Cutter max. revolution n (min <sup>-1</sup> )
25	59,000 (Long shank : 49,000)
28	54,000
32	49,000
35	46,000 (Long shank : 39,000)
40	42,000
50	36,000

## Maximum revolution without balance adjustment in combination with arbor

Cutting diameter DC (mm)	Cutter max. revolution n (min <sup>-1</sup> )
25	12,500
28	11,500
32	9,600
35	8,800
40	7,700
50	6,300

## Case study

### Industrial machine parts AlMg2.5

Vc = 1,500 m/min (n = 9,550 min<sup>-1</sup>)  
 1. ap x ae = 3 x 40 mm  
 fz = 0.2 mm/t (Vf = 7,640 mm/min)  
 2. ap x ae = 8 x 5 mm  
 fz = 0.2 mm/t (Vf = 7,640 mm/min)  
 3. ap x ae = 2 x 50 mm  
 fz = 0.15 mm/t (Vf = 5,730 mm/min)  
 Wet  
 MEAS050R-13-4T-M  
 KCGT130504FR-AL PDL025

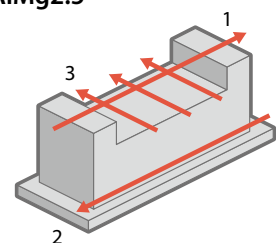

### Cutting time

MEAS ø50-4T

**190 Sec**

50%

Competitor C ø50-3T

**430 Sec**

MEAS showed 50% faster cycle time or more compared to competitor C

(User evaluation)

## Ramping reference data

Cutting dia. DC (mm)	25	28	32	35	40	50	63	80
Max. ramping angle RMPX	20°	16°	12.5°	11°	8.5°	6°	3.9°	2.8°
tan RMPX	0.363	0.287	0.221	0.194	0.149	0.105	0.068	0.049

## Ramping tips

Recommended ramping angle is  $\leq$  RMPX  
(see chart above for recommended ramp angle)  
Reduce recommended feed rate by 50%

Max. cutting length (L) at max. ramping angle

$$L = \frac{ap}{\tan \text{RMPX}}$$

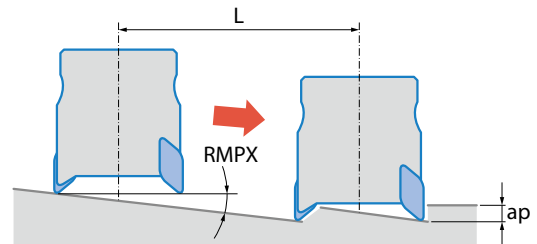

## Plunging tips

Reduce feed rate to  $fz \leq 0.1 \text{ mm/t}$  when plunging

Insert description	Maximum width of cut (ae)
KCGT13 type	8 mm

## Helical milling tips

For helical milling, use between min. cutting diameter and max. cutting diameter

### Exceeding max. cutting diameter

Center core remains after machining

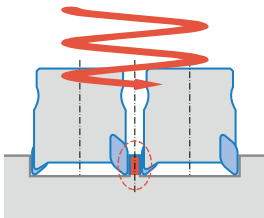

Description	Min. cutting diameter	Max. cutting diameter	Maximum ramping depth per cycle
MEAS...13...	2×DC-16	2×DC-3	3.5

Unit: mm

### Under min. cutting diameter

Center core hits holder body

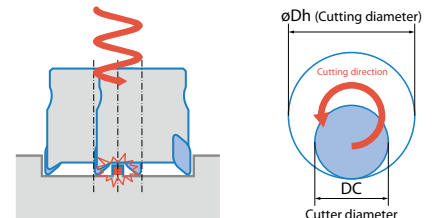

- Use down cut (Refer to detail on right)
- Feed rates should be reduced to 50% of recommended cutting
- Use caution to eliminate incidences caused by producing long chips

## Peck milling tips

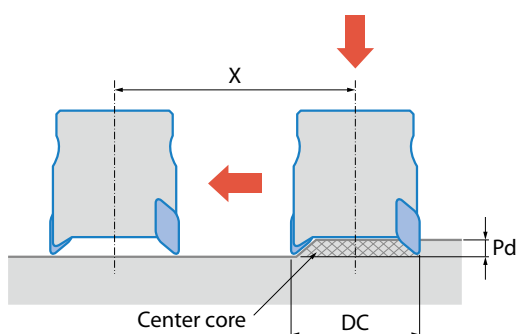

### Peck milling depth

Please refer to the figure above (Pd: Max. pecking depth)  
Traversing after drilling

1. It is recommended to reduce feed by  $fz = 0.15 \text{ (mm/t)}$  or less until the center core is removed
2. Axial feed rate recommendation per revolution is  $f = 0.1 \text{ mm/rev}$  or less

Description	Max. drilling depth Pd	Min. cutting length X for flat bottom surface
MEAS...13...	3.5	DC-16

Unit: mm

## How to mount inserts

1. Completely eliminate chips and dust from the insert mounting side
2. Insert screw
  - Coat anti-seize compound (P-37) thinly on portion of taper and thread
  - Attach screw to the magnetized wrench tip and tighten while gently pressing the outside edge of the insert toward the insert pocket surface (grooved surface). See the picture on the right. Recommended torque 3.5 N·m



## When using inserts with a corner-R(RE) of 3.2 or larger

When using inserts with corner-R(RE) 3.2 or larger, additional modifications of the cutter body will be necessary.

Additional modifications for the body will be necessary.

Ref. to the chart below for the recommended modifications.

After the additional modifications, adjust the balance grade to G6.3 at a speed of 10,000 min<sup>-1</sup>.

Make sure that there is no burr on the insert pocket surface (grooved surface).

(If corner-R is 3.0 mm or smaller, additional modifications are not needed.)

Insert corner-R(RE) (mm)	Additional processing dimension to body corner (mm)
3.2	R2.0
4.0	R2.5
5.0	R3.0

\* Round-shaped additional processing is recommended.  
Do not make any additional chamfering.

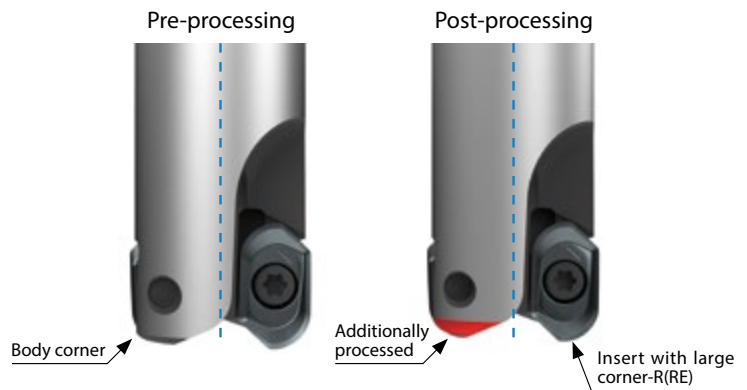

## Cautions

### While in use



**Please use within recommended cutting conditions**

**Do not run the cutter at revolutions exceeding the printed maximum revolution limit of the cutter body**

Inserts may be damaged due to the centrifugal force and cutting load.

**Please do not use under the following conditions:**

When cutter is not fully loaded with inserts if the body is damaged.

**Please wear protective equipment such as protective glove when changing inserts**

Injury can occur when touching the cutting edge.

### Dynamic balance

**Balance adjustment on the cutter is completed before shipping**

Balance adjustment has been made with special high precision inserts to be ISO balance grade (ISO1940/1) G6.3

When using at a higher revolution (10,000min<sup>-1</sup> or over), refer to the table below to adjust the balance of MEAS and arbor

**Do not operate the balance adjustment screw on the outer periphery of the cutter. This could lead to improper dynamic balance**

